

---

# XAS 188 CAT USA

---

Portable compressor



---

## Standard Scope of Supply

---

The Atlas Copco **XAS 188** is a single-stage oil-injected rotary screw type air compressor, powered by a liquid-cooled, four cylinder diesel engine.

The unit consists of an air end, diesel engine, cooling circuit, air/oil separation and control systems - all enclosed within a sound dampened HardHat™ polyethylene shell.

Unique features – 110% fluid containment, internal toolbox, external lifting eye, new easy to use controller XC1004

---

## Available Models

---

XAS 188

single stage - 100 psi – Caterpillar engine

---

## Standard Features

- Latest Atlas Copco screw technology
- 110% Spillage Free Containment Frame
- Xc1004 controller
- Heavy Duty Single Axle Trailer w/ 15" tires
- Internal tool box
- Spin on type compressor oil separator
- HardHat™ Enclosure
- External lifting eye
- Cold weather package
- 1500 hrs / 2 years compressor service interval

---

## Benefits

- 189 CFM free air delivery @ 2.37Gal/hr (8.97L/hr)
- Protects environment from spill/ leaks, avoids costly clean up
- Easy to use, one controller to regulate the entire machine
- Well balanced for safer towing or moving around site
- High ground clearance for rough site and road conditions
- Internal Tool Box – Fits 90 lb hammer fit all you need inside the lockable compressor
- Less than one hour service with no special tools required
- Heavy duty double wall polyethylene enclosure
- Dent and UV Resistant
- Keeps looking new for longer and adds to resale value
- Easy access for getting on/off site
- Features required for starting at -13°F and cold weather operations. Includes: 120V block heater, synthetic compressor oil, closed circuit breather kit (CCVI), coolant).
- Lower cost of ownership and increase your uptime

## Optional Features

## Benefits

- Extended Draw bar with hose reel
  - Lubricator
  - Safety cartridge
  - Undercarriage variants and add-ons
  - OSHA valve
  - FleetLink
  - Battery disconnect
- Keeps all of the customer's hoses in the same place, great for municipal bids. It comes as 50' or 100' Single Hose Reel or Dual Hose Reel
  - Ensure effective lubrication of all compressed air tools, improves the functioning of pneumatic equipment while reducing the wear and tear
  - To offer extra filtration, safer operations and you it gives the option to change the air filter without stopping the machine
  - Electric brakes, Hydraulic brakes, jockey wheel, frame D Rings, support mount, several types of loose ball couplings (2 5/16", 2" and 2" bulldog), 6 way trailer end.
  - OSHA compressed air safety shut-off valves immediately shut off the air supply should the volume of air flowing through the valve exceed a preset value. (For example: when an air hose breaks)
  - FleetLink is an intelligent telematics system that helps optimize fleet usage; reduce maintenance cost, ultimately saving time and money. It allows you to manage your machines conveniently wherever you are, always having the latest fleet information at hand.
  - Prevents battery power loss when machinery not being used

## Technical Data

Compressor	Units	XAS 188 CD8 T4F
Actual free air delivery <sup>1</sup> (FAD)	cfm	189
Normal effective working pressure	Psi	100
Maximum unloading pressure	Psi	125
Minimum working pressure	Psi	58
Max. sound pressure level @ 23' (7m) at normal working speed & pressure <sup>2</sup>	dB(a)	76
Compression Stages		1
Air Receiver Capacity	US Gal (L)	4.76 (18.0)
Compressor oil capacity	US Gal (L)	2.57 (9.75)
Approximate air outlet temperature	°F (°C)	200 (93)
Air Compressor outlets		2 x ¾"
Max. ambient temperature (at sea level) <sup>3</sup>	°F (°C)	122 (50)
Maximum altitude	ft (m)	9842 (3000)
Minimum starting temperature (with cold weather as standard)	°F (°C)	-13 (-25)

Engine	Caterpillar	C2.2T
Emissions Regulation	US EPA	Tier 4 Final
US EPA Engine Family		KH3XL2.22TD7
Output at rated speed (2700 rpm) <sup>4</sup>	HP	48.8
Number of cylinders		4
Aspiration		Turbocharged
Displacement	cu in (L)	135 (2.21)
Engine speed (Unloaded)	rpm	1600
Engine speed (Maximum load)	rpm	2450
Engine oil capacity	US Gal (L)	2.05 (7.76)
Engine coolant capacity	US Gal (L)	3.5 (13.2)
Fuel tank capacity	US Gal (L)	27 (102)
Fuel consumption at 100% load	Gal/Hr (L/Hr)	2.37 (8.97)
Fuel consumption at 75% load	Gal/Hr (L/Hr)	1.92 (7.27)
Fuel consumption at 50% load	Gal/Hr (L/Hr)	1.69 (6.40)
Fuel consumption at 25% load	Gal/Hr (L/Hr)	1.24 (4.69)
Fuel consumption at 0% load	Gal/Hr (L/Hr)	1.02 (3.86)
Electrical System (Negative Ground)	V	12
Battery Capacity (Cold Cranking Amps <sup>5</sup> )	A	725

<sup>1</sup> According to ISO 1217 ed.3 1996 annex D

<sup>2</sup> Measured in accordance with ISO 2151 under free field conditions @ 7m distance

<sup>3</sup> Consult Atlas Copco for proper de-rating instructions for operation beyond ambient limitations

<sup>4</sup> Horsepower limited by Engine ECU

<sup>5</sup> According to DIN 72311

## Dimensions

### Trailer mounted - HardHat™ Version

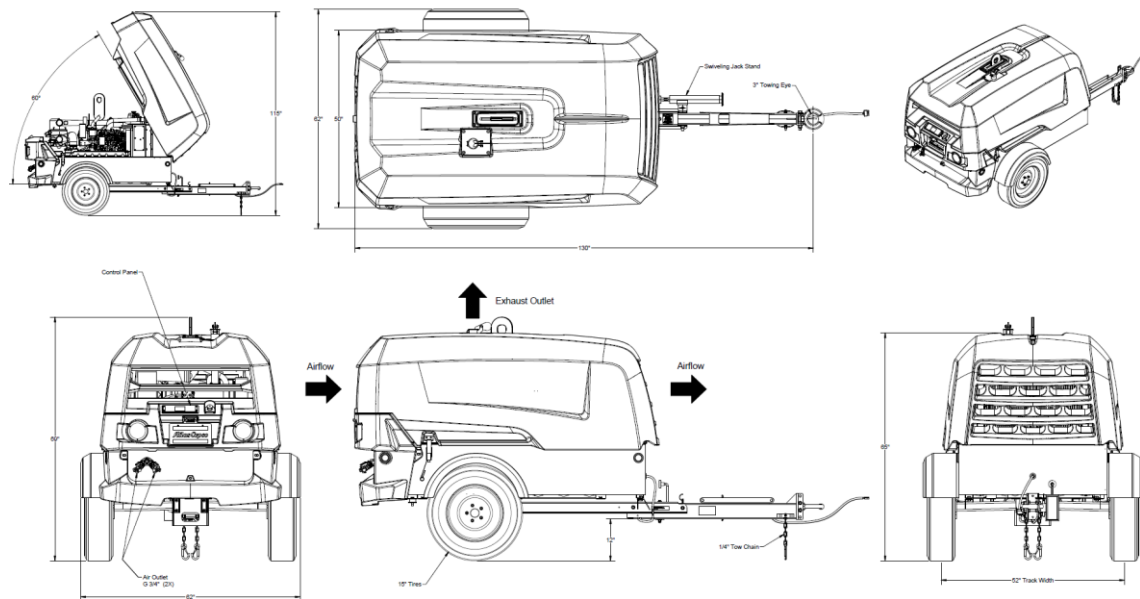

### Weight (Wet - Ready-to-operate)

		XAS 188 CD8
Trailer mounted	lb (Kg)	2149 (975)

### Dimensions

		XAS 188 CD8
Trailer mounted Inches (m)	L x W x H	130 (3.3) x 62 (1.57) x 69 (1.75)

### ALTITUDE UNIT PERFORMANCE CURVE

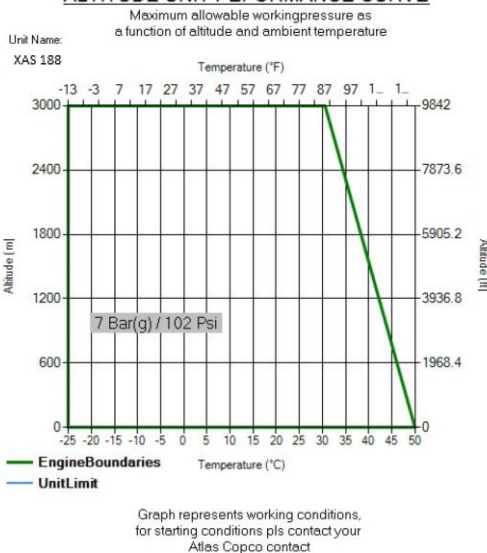

## Principle Data

### Compressor Element

The XAS 188 compressor utilizes Atlas Copco's new C-90 element that is driven from the diesel engine with coupling. Our new element brings even more flow with less fuel consumption.

Inlet air is filtered through a heavy-duty two-stage air filter.

### Air/Oil Separator

Air and oil separation is achieved through a centrifugal compressor oil separator with a spin on type filter element for easy maintenance. Separators are ASME/CRN approved versions and are stamped accordingly.

The separator is equipped with a sealed high-pressure safety relief valve, sonic nozzle, automatic blow-down valve, and pressure regulator.

Easy to service, just one hour service, no special tools and up to 1500 hour / 2 years compressor service interval.

#### Air/Oil Separator Tank:

Volume	4.76 US Gal / 18 L
Certifications	ASME / CRN
MAWP	261psi @ 248°F

### Cooling System

The cooling system consists of integrated side-by-side aluminum oil cooler with axial fan to ensure optimum cooling. A guard for operator safety protects the fan. There is an access port on both sides of the fan box for easy cleaning

The cooling system is suitably designed for continuous operation in ambient conditions up to 122°F, with canopy door always closed.

### Compressor Regulating System

The compressor regulating system consists of air receiver/oil separator, compressor element, blow down valve and pressure safety valve.

Economic power consumption is assured by the fully automatic 100% step-less speed regulator that adapts engine speed to air demand.

### Discharge Outlets

Compressed air is available from 2 x 3/4" outlet valves, with claw type (Chicago) coupling.

### Storage Compartment

The compressor has a built in open top tool box compartment. Tool box dimension is: **33.8" L x 7.4" W x 10" H**.

### Safety Features

The compressor has many safety features: Pressure safety valve, emergency shut down button, low fuel shut down, high temperature engine coolant, high temperature compressor oil and engine oil pressure

## Engine

### Caterpillar C2.2T

Caterpillar C2.2T Tier 4 Final, turbocharged, four-cylinder, liquid-cooled diesel engine provides ample power to operate the compressor continuously at full-load.

Meets all US EPA and Environment Canada exhaust legislations with Tier 4 Final compliance. The US EPA engine family is "KH3XL2.22TD7". The engine utilizes a DOC to meet Tier 4 Final emissions. All functionality of the engine and exhaust after treatment are controlled automatically on the XC1004 controller.

Engine output at rated speed, in accordance to SAE Standard, is 49hp at 2450 rpm, as limited by the engine ECU.

The engine has the capability to start the compressor to -13°F (-25°C) due to standard cold start package included.

The 27 Gal (102L) fuel tank is sufficiently sized to operate the unit for 11 hours at full-load condition.

## Electrical System

The **XAS 188** is equipped with a 12 Volt negative ground electrical starting system.

## Instrumentation

The instrument control panel is located on the back, of the compressor canopy with easy access.

Standard instrument package includes an operating pressure gauge, and fully diagnostic ECU controller with large 3.5" display. The intuitive Atlas Copco XC1004 controller is easy to operate with all functions conveniently at your fingertips. The controller also manages the engine ECU operating system, and a number of safety warnings and shut downs on various parameters (listed below).

### XC1004 Controller Functionality:

- Displayed while running
  - Hours
  - Fuel level
  - RPM
  - Outlet pressure
- Operational Buttons
  - Start and stop of the unit
  - View measurements, settings and alarms
  - Graphical representations of the alarms
- Compressor measurements displayed
  - Running hours
  - Fuel level
  - Battery voltage
  - Running hours
  - Regulating pressure
  - Minor and major service counters in hours and days
  - Compressor element temperature
- Engine measurements displayed
  - Current fuel level
  - Engine coolant temperature
  - Engine oil pressure
  - Engine RPM
- Warnings and Shutdowns
  - High temperature engine coolant
  - High temperature compressor oil
  - Engine oil pressure
  - Low fuel level
- Alarms
  - View current & historical alarms present
  - DM1: View current engine codes (SPN/FMI)
- Settings
  - Reset service timers
  - Diagnostics for engine ECU
  - Unit of measure changes



## Bodywork

---

The compressor is delivered in the HardHat™ version.

**HardHat™:** Our HardHat™ version comes standard with dual wall, Polyethylene material providing superior corrosion, and UV protection against fading and discoloration. As well as unmatched dent and damage resistance. The canopy is sound attenuated to meet the most current legal noise requirements. A clamshell style hood offers easy service access to all components.

## Undercarriage

---

The **XAS 188** compressor is available with undercarriage alternatives, providing utmost flexibility in installation or towing requirements.

- Single axle trailer setup with:
  - US DOT/Federal MVSS 49CFR571 approved light package and 4 way trailer plug
  - Adjustable height pintle hitch (3" lunette)
  - 15" Rims w/ ST205/75D15 Tires for trailer use
  - Trailer brakes not standard (can be added as option)
  - Heavy Duty torsion axle rated at 2,500lbs
  - Safety chains
  - Screw jack leveling
  - Single point lifting structure
  
- Undercarriage options
  - Loose Ball Coupling 2 5/6"
  - Loose Ball Coupling 2"
  - Loose Ball Coupler 2" Bulldog
  - Electric Brake
  - Hydraulic Brake

## Manufacturing & Environmental Standards

---

The **XAS 188** is manufactured following stringent ISO 9001 regulations, and by a fully implemented Environmental Management System fulfilling ISO 14001 requirements.

Attention has been given to ensure minimum negative impact to the environment.

The **XAS 188** meets all current US EPA, CARB and Environment Canada exhaust and noise emission directives.



## Supplied Documentation

---

The unit is delivered with documentation regarding:

- Hard copies of the Atlas Copco Operators Safety and Instruction Manual, Atlas Copco Parts Book, as well as electronic copies available on request.
- Warranty Registration card for engine and Atlas Copco Compressor (Units must be registered upon receipt).
- Certificate for air/oil separator vessel and safety valve approval, ASME/CRN (Upon request only).

## Warranty Coverage

---

**Caterpillar Engine:** Caterpillar Diesel engines are warranted to be free from defects with regard to material and workmanship for the period of twelve (12) months, with unlimited running hours from the date of invoicing from Atlas Copco or up to twenty-four (24) months and prior to the accumulation of 2000 hours of use, whichever occurs first

**Atlas Copco Compressor:** Warrantied to be free from defects with regard to material and workmanship for the period of eighteen (18) months from date of shipment from the factory, or twelve (12) months from date of initial start-up, whichever occurs first, without limitation of running hours.

Air compressor element assemblies used in Atlas Copco portable air compressors, is warranted to be free from defects with regard to materials and workmanship for the period of thirty (30) months from date of shipment from the factory, or twenty four (24) months from date of initial start up, whichever occurs first, without limitation of running hours. Atlas Copco service kits including parts and oils (PAR Oil's) must be used to maintain warranty. Failure to register warranty upon initial start-up may cause warranty claim delays or rejection of claims.

**Extended Warranty Programs:** Programs are available; please contact your local sales representative for more info.